

2025/01

中国制造年，对于一个企业来讲，既短暂而又漫长。

有的粉墨登场，也有的悄然谢幕，更有的徘徊迷茫

还有的则在演绎着自然界“物竞天择、适者生存”的游戏规则。

铂仲科技 梦想启航



FA-自动化组件/铂仲精品



东莞市铂仲自动化科技有限公司

Dongguan Platinum Zhong Automation Technology Co., Ltd.

地址: 广东省东莞市长安镇沙头南区沙涌路13号

电话: 0769-81555017 TEL:18826857178(李生)/18681169528(曹生)

网址: www.bzconveyor.com

东莞市铂仲自动化科技有限公司

Dongguan Platinum Zhong Automation Technology Co., Ltd.

<http://www.bzconveyor.com>

公司简介 >>>>>> Company profile

本公司成立于2018年6月，座落于珠三角生产与制造中心 - 东莞市·长安镇；公司是一家集研发、生产制造、销售、服务为一体的综合型企业。公司拥有专业的研发技术团队、先进的生产加工设备、整洁的车间和仓储中心，建立起完善的产品检验流程和质量保证系统。公司创始团队都是有着十几年自动化行业结构设计经验，我们将致力于模块化的精密标准输送组件及物流组件的开发与生产，为客户解决模块化的机械工作站及组件类的传动机构，减少客户单项产品的设计选型和采购装配成本，有效的提升整机装配及调试效率。我们秉承品质第一，诚信为本，卓越创新，精益求精的经营理念，为您提供一站式的精密输送系统与物流组件的专业配套服务。

企 业 精 神

我们以工匠精神致力于精密传动部件
We devote ourselves to precision
transmission parts in the spirit of craftsmen

服务宗旨 >>>>>> Service tenet

品质为根 诚信为本
匠心智造 创新为魂

您为红花

我们做好绿叶



若精彩--蝶自飞来!
中国·东莞



精密输送机-全型材-宽度选择型

BQT01

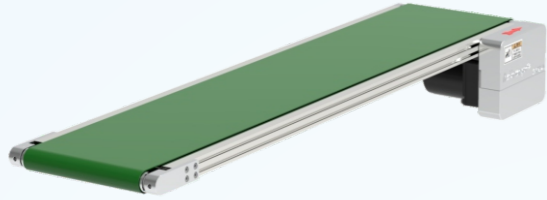

《头部驱动》带轮直径 $\phi 30\text{mm}$

[非防跑偏型]

BQT51

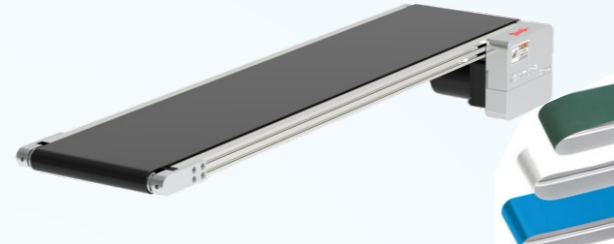

《头部驱动》带轮直径 $\phi 30\text{mm}$

[防跑偏型-平皮带肋条]

BQZ01

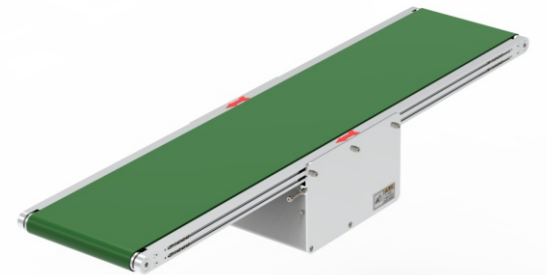

《中间驱动》带轮直径 $\phi 30\text{mm}$

[非防跑偏型]

BQZ51

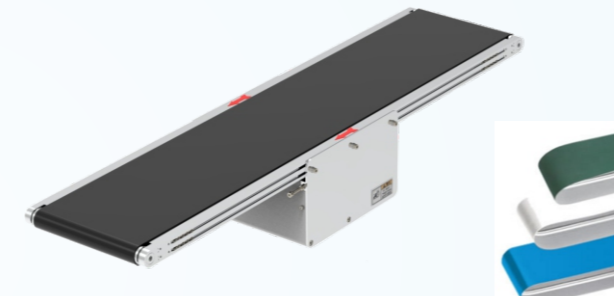

《中间驱动》带轮直径 $\phi 30\text{mm}$

[防跑偏型-平皮带肋条]

输送机专用铝型材 型号:BZ-3090、BZ-30140、BZ-30190、BZ-30240、BZ-30290

B=50时

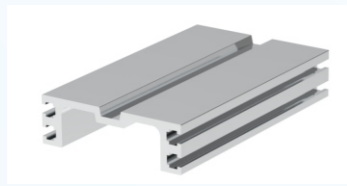

B=100时

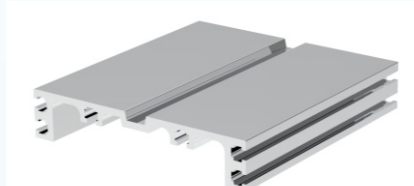

B=50时

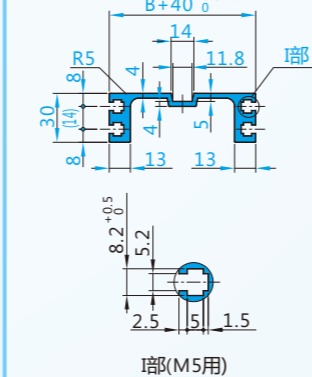

B=100~250时

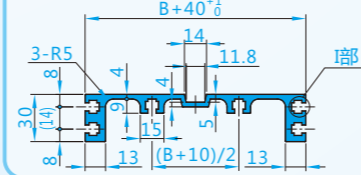

[全型材-截面图]

B=150时

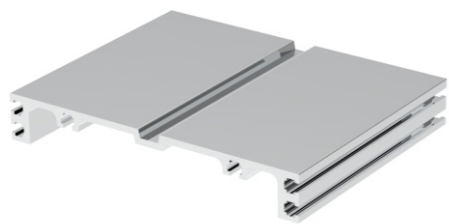

组合公用

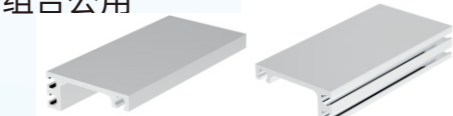

B=200时

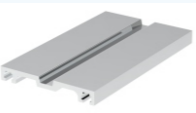

B=250时

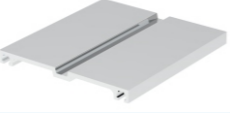

[全铝型材]

精密输送机-经济型-宽度自由指定型

BET01

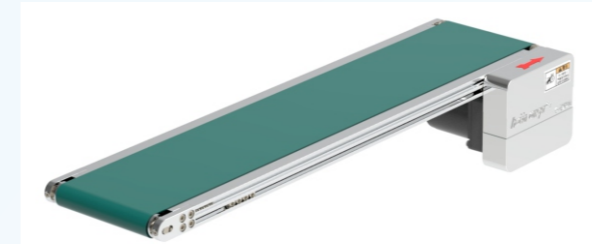

《头部驱动》带轮直径 $\phi 30\text{mm}$

[非防跑偏型]

RFT51

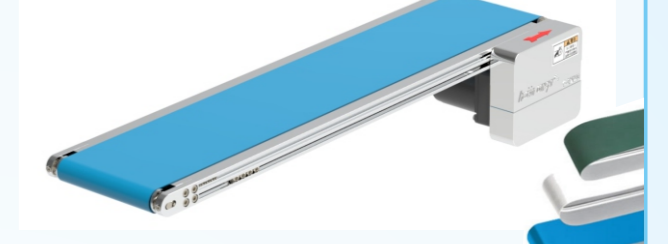

《头部驱动》带轮直径 $\phi 30\text{mm}$

[防跑偏型-平皮带肋条]

BEZ01

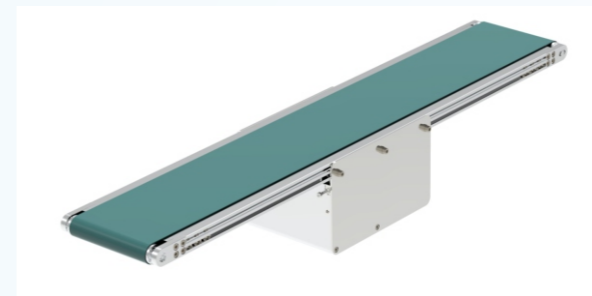

《中间驱动》带轮直径 $\phi 30\text{mm}$

[非防跑偏型]

BEZ51

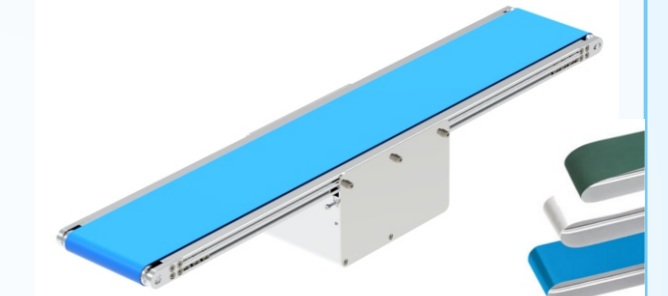

《中间驱动》带轮直径 $\phi 30\text{mm}$

[防跑偏型-平皮带肋条]

BETQ01

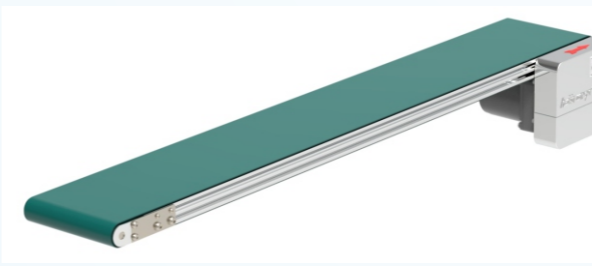

《头部驱动》带轮直径 $\phi 30\text{mm}$

[非防跑偏皮带全包型]

BETQ51

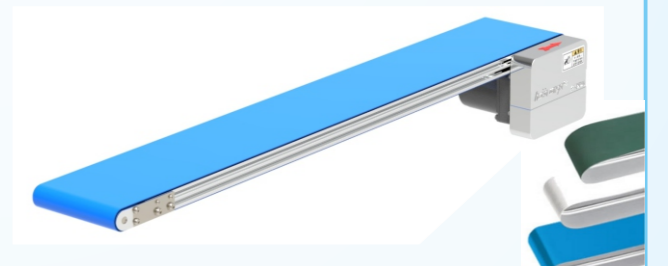

《头部驱动》带轮直径 $\phi 30\text{mm}$

[防跑偏皮带全包型-平皮带肋条]

输送机专用铝型材 型号:BZ-2628

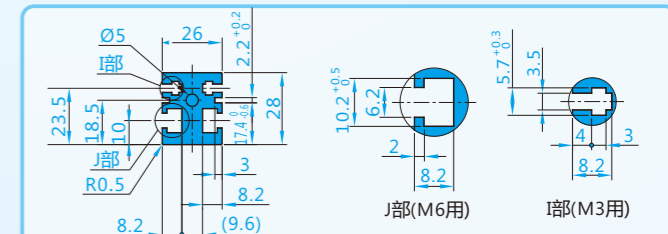

精密输送机-中负载型-宽度自由指定型

BWT01

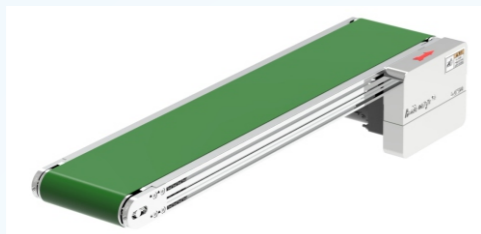

《头部驱动》带轮直径 $\phi 50\text{mm}$

[非防跑偏型]

BWT51

订单：10天

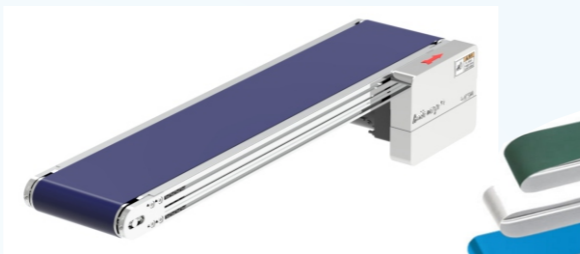

《头部驱动》带轮直径 $\phi 50\text{mm}$

[防跑偏型-平皮带肋条]

BWZ01

订单：10天



《中间驱动》带轮直径 $\phi 50\text{mm}$

[非防跑偏型]

BWZ51

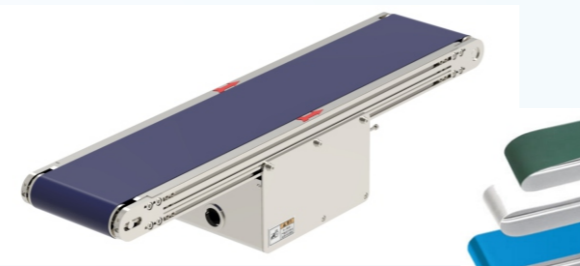

《中间驱动》带轮直径 $\phi 50\text{mm}$

[防跑偏型-平皮带肋条]

BWQTQ01

交期：7天



《头部驱动》带轮直径 $\phi 50\text{mm}$

[非防跑偏皮带全包型]

BWQTQ51

订单：10天 交期：7天

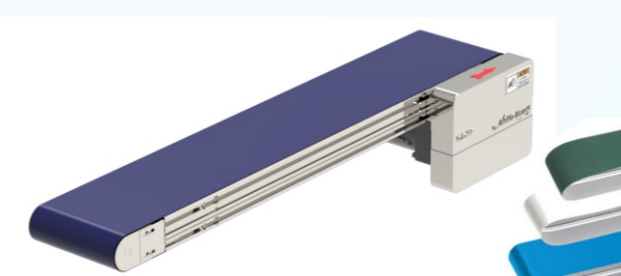

《头部驱动》带轮直径 $\phi 50\text{mm}$

[防跑偏皮带全包型-平皮带肋条]

精密输送机-重负载型-高输出型

BGT01

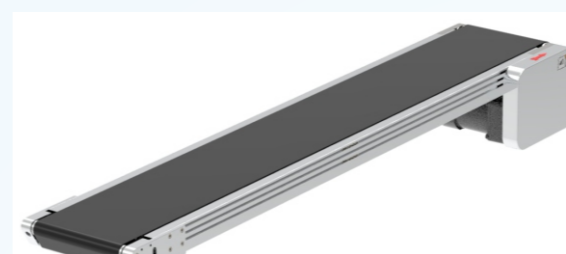

《头部驱动》带轮直径 $\phi 60\text{mm}/\phi 30\text{mm}$

[非防跑偏型]

BGT51

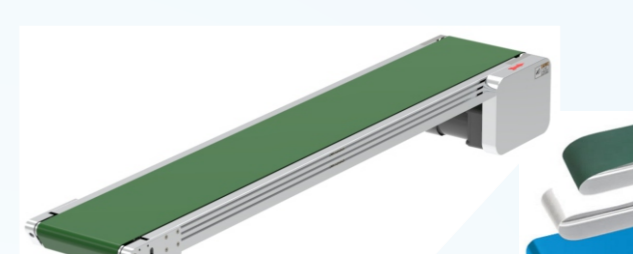

《头部驱动》带轮直径 $\phi 60\text{mm}/\phi 30\text{mm}$

[防跑偏型-平皮带肋条]

BGZ01

交期：7天

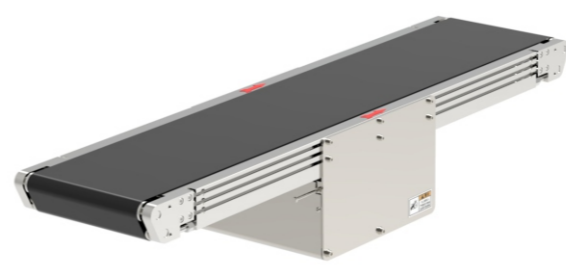

《中间驱动》带轮直径 $\phi 60\text{mm}/\phi 30\text{mm}$

[非防跑偏型]

BGZ51

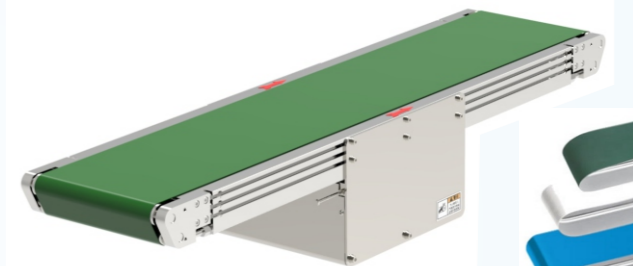

《中间驱动》带轮直径 $\phi 60\text{mm}/\phi 30\text{mm}$

[防跑偏型-平皮带肋条]

输送机专用铝型材 型号:BZ-3049

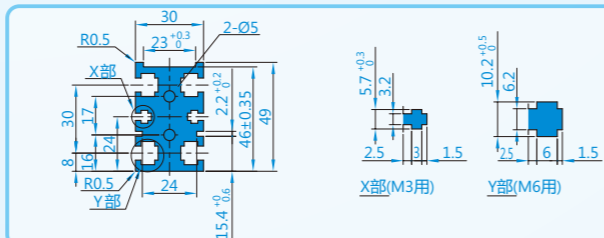

输送机专用铝型材 型号:BZ-3059

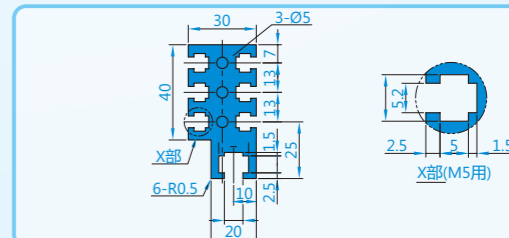
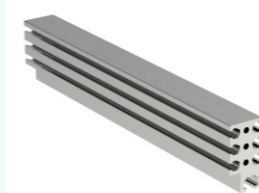

精密输送机-同步带-长/宽度自由指定型

BTT01



《头部驱动》带轮直径 $\phi 20\text{mm}$

[同步带单列型]

BTZ02

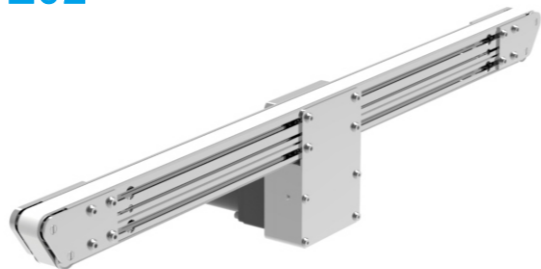

《中间驱动》带轮直径 $\phi 20\text{mm}$

[同步带单列型]

BTT06



《头部驱动》带轮直径 $\phi 30\text{mm}$

[同步带双列标准型]

BTZ07

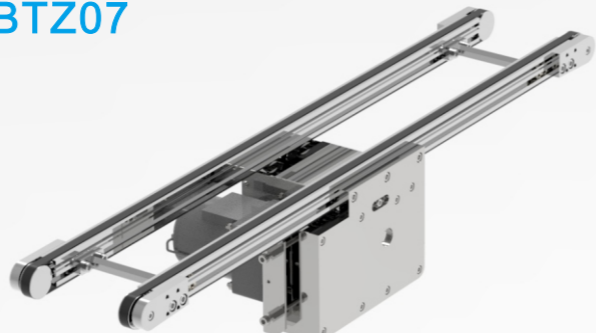

《中间驱动》带轮直径 $\phi 30\text{mm}$

[同步带双列标准型]

BTT11



《头部驱动》带轮直径 $\phi 50\text{mm}$

[同步带双列型]

BTZ12



《中间驱动》带轮直径 $\phi 50\text{mm}$

[同步带双列型]

输送机专用铝型材 型号:BZ-3049

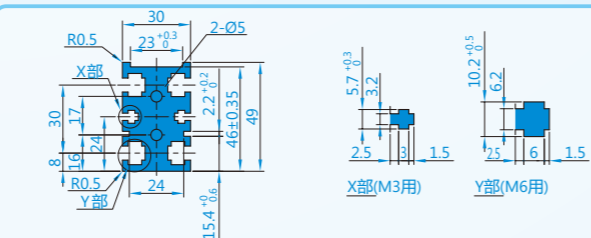
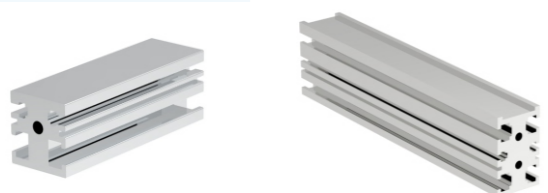

精密输送机-平皮带/塑料链-环型线

BPT01



可自由组合环型线-附加转角装置

[箱式双列平皮带型]

BPT02



《头部驱动》带轮直径 $\phi 57\text{mm}$

[平皮带双列型]

BPZ06

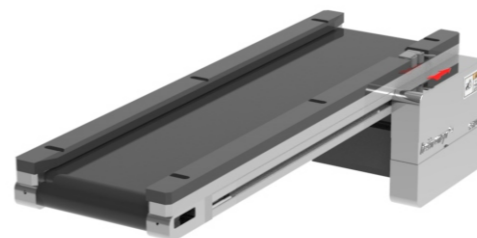

《头部驱动》带轮直径 $\phi 48\text{mm}$

[带挡边安装平皮带型]

BPZ07



《头部驱动》带轮直径 $\phi 57\text{mm}$

[塑料链双列型]

输送机专用铝型材 型号:BZ-3059

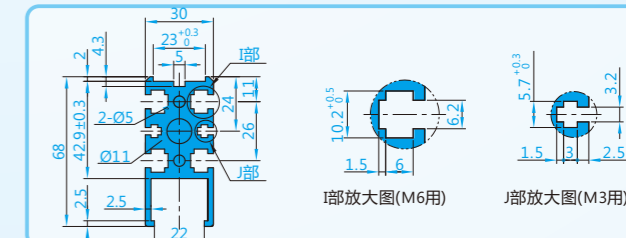

精密输送机-伺服铁氟龙网带（案例）

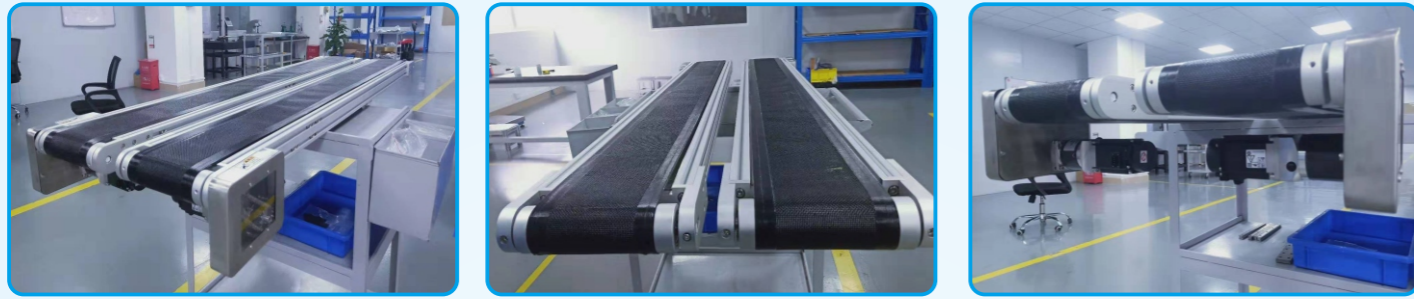

精密输送机-高输出加宽型（案例）



精密输送机-制具式平皮带双列环型线（案例）

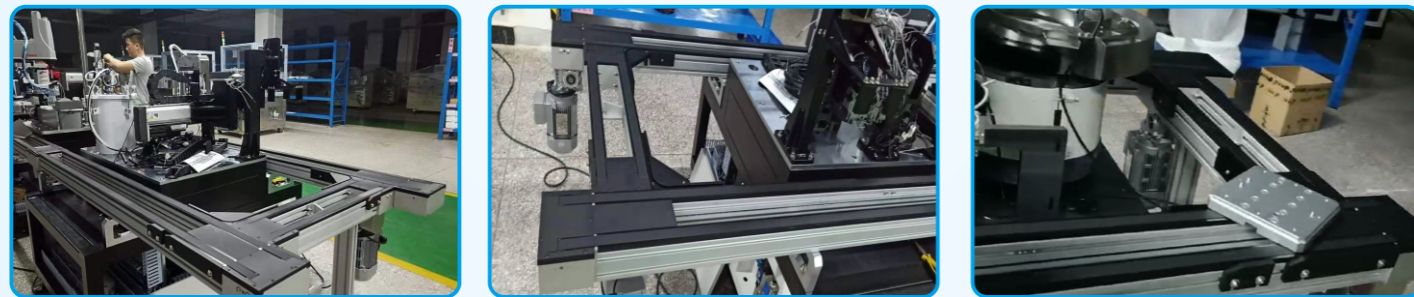

精密输送机-电机外装/双列平皮带/步进电机型（案例）



精密输送机-支座



[I型]



[H型]



[M型]

精密输送机-安装角座

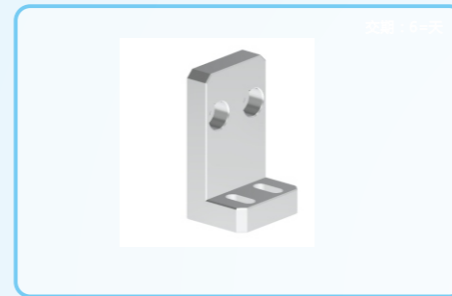

[L型-标准]



[L型-重载]



[L型-角度调整]

精密输送机-挡边

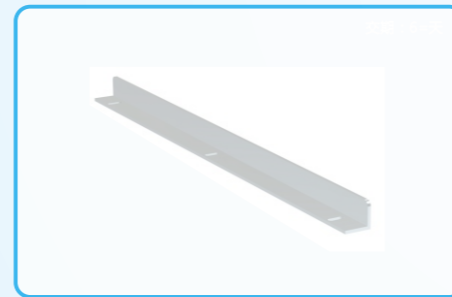

[L型角铝-标准]



[流利条型]

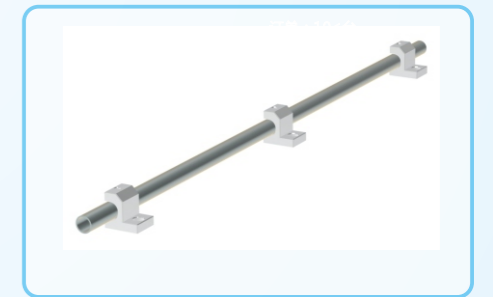

[夹持管组件型]

精密输送机-止回组件/自动锁扣



[侧面孔型]



[π型]

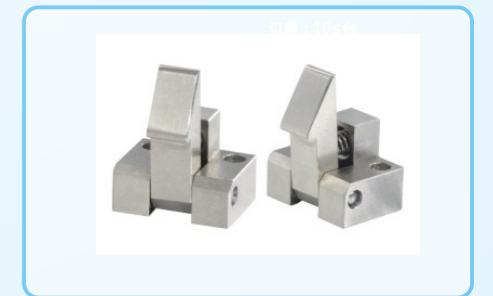

[自动锁扣]

无油衬套



铜合金直柱型



铜合金带肩型



铜合金止推型



铜合金标准法兰型

无油衬套组件-标准型



圆法兰型-单/双衬型



对边法兰型-单/双衬型



方法兰型-单/双衬型

无油衬套组件-嵌入型



圆法兰型



对边法兰型



方法兰型

无油衬套组件-中间型



圆法兰型



对边法兰型



方法兰型

无油衬套组件-方型固定座



加高方型 单挡圈型



加高方型 双挡圈型



加宽方型 双挡圈型

直线轴承-直柱型



单衬型/双衬型



短型/中型



紧凑单衬型/双衬型



开口/间隙调整 单衬型

带法兰直线轴承组件-标准型



圆法兰型-单/双衬型



对边法兰型-单/双衬型



方法兰型-单/双衬型

带法兰直线轴承组件-嵌入型



圆法兰型-单/双衬型



对边法兰型-单/双衬型



方法兰型-单/双衬型

带法兰直线轴承组件-中间型



圆法兰型-双衬型



对边法兰型-双衬型



方法兰型-双衬型

带法兰直线轴承组件-方型固定座



SBR箱式单元导轨



加宽方型 单衬型



轴滑动型 单衬型/双衬型

加工中心-车间（一）



加工中心-车间（二）



机加工产品（一）

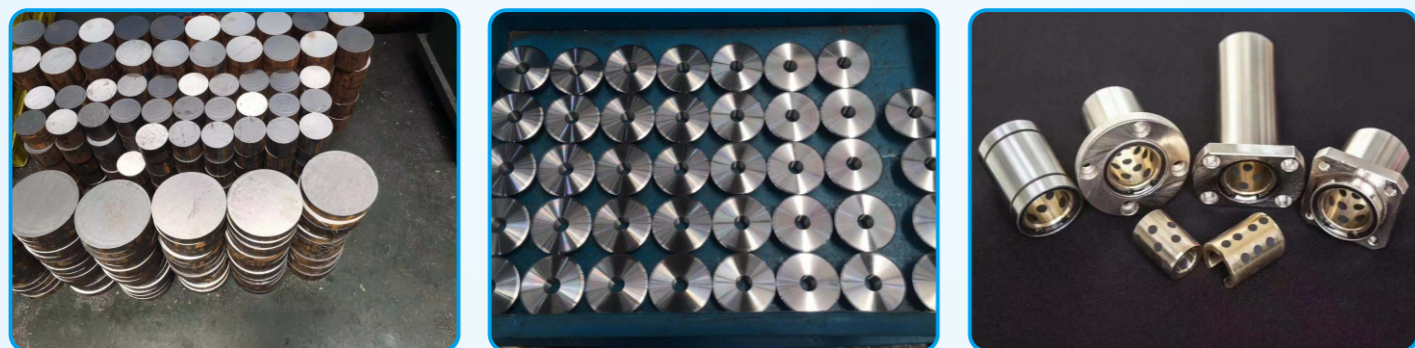

机加工产品（二）



公司环境



装配/仓库/品质中心



办公一角

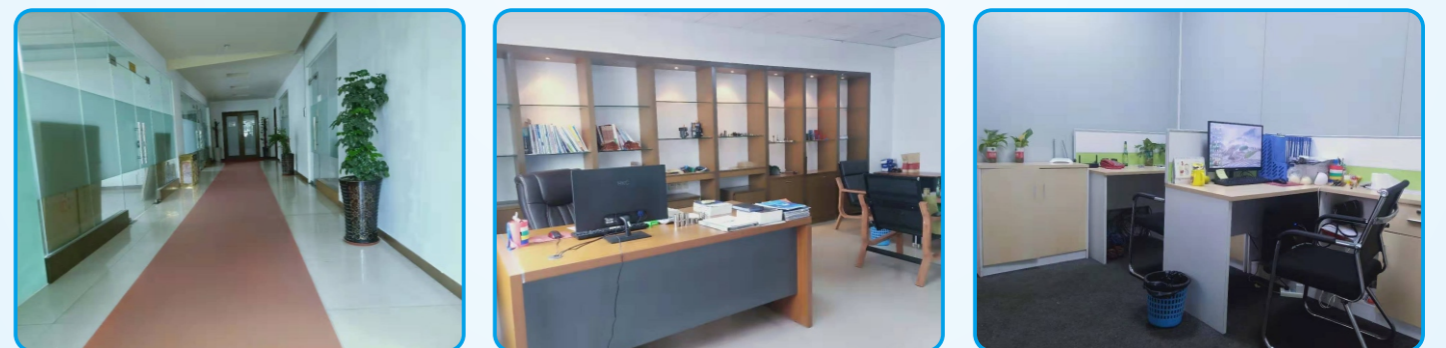

我们的团队

